



**SUBARU**

PART NUMBER: E361SXA201

**INSTALLATION  
INSTRUCTIONS**

DESCRIPTION: KAYAK CARRIER

**A** KIT CONTENTS:

①

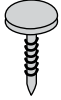

Plug 16x

②

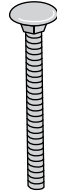

Long Carriage Bolt 4x

③

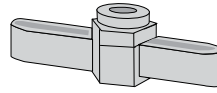

Hex Key 4x

④

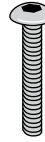

Button Head Screw 4x

⑤

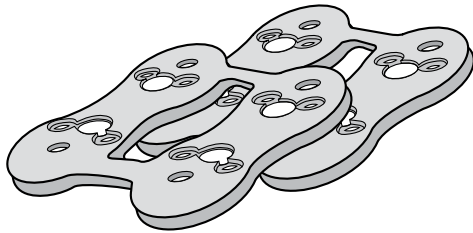

Pad 2x

⑥

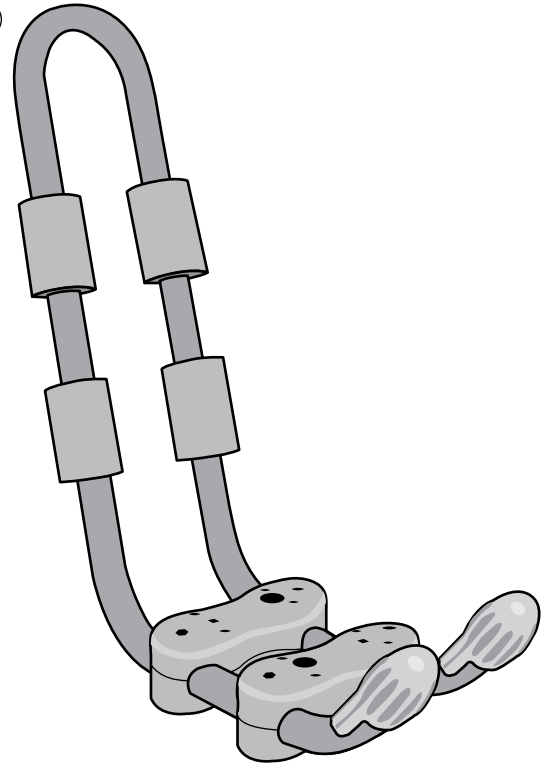

BASE 2x

⑦

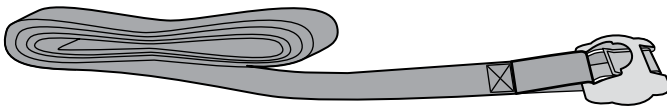

Strap 2x

⑧



Over-Molded Wrench 1x

⑨

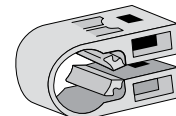

SnapAround 4x



**SUBARU**

PART NUMBER: E361SXA201

**INSTALLATION  
INSTRUCTIONS**

DESCRIPTION: KAYAK CARRIER

**Important Notes:**



- Minimum crossbar spread of 24". If spread is less than 24", adjust crossbars.
- Must use front and rear tiedowns. Failure to secure front and rear of kayak to ends of vehicle can result in property damage, personal injury or death.
- Do not exceed the weight limit of you roof rack as indicated in the owner's manual. **MAXIMUM KAYAK WEIGHT: 80 LBS.**

**DO YOU HAVE - SQUARE - ROUND - OR FACTORY CROSSBARS?**

**Step 1**

**(SQUARE BARS ONLY)**

Loosen the tabs in the SnapArounds by bending them repeatedly.

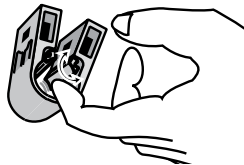

Remove the tabs with scissors or pliers.

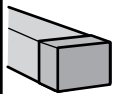
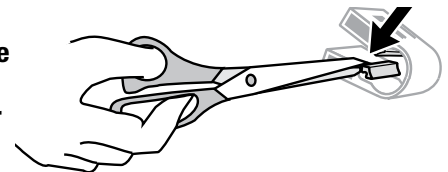

ATTACH 2 SNAPAROUNDS ONTO EACH BAR...

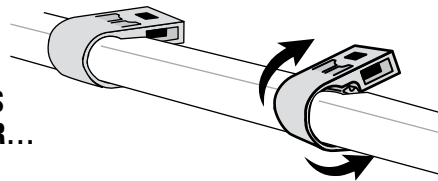

...CONTINUE TO STEP 2 (FOR SQUARE BARS).

**Step 1**

**(AERO BARS ONLY)**

Attach SnapArounds or crossbar clamps in the same direction on each bar.

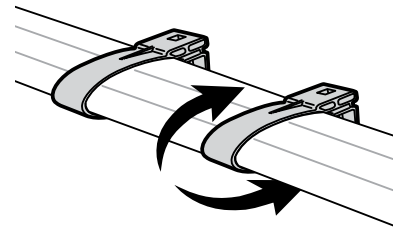

**Step 2**

**(AERO BARS & SQUARE BARS ONLY)**

**CHOOSE CARRIER POSITION ON VEHICLE.**

*Large round holes in bases must face the rear of the vehicle.*

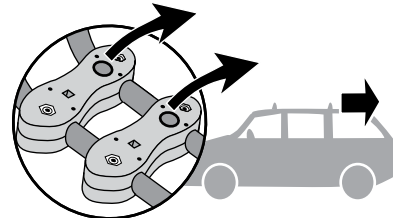

Remove one base top and bottom.

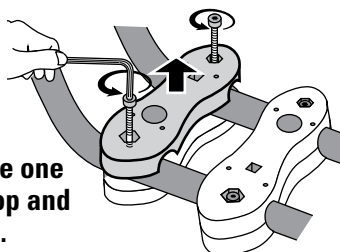

- Reinstall bases with square holes and round holes aligned.
- **TIGHTEN** completely.
- Continue to step 3.

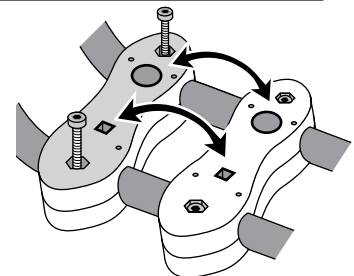



**SUBARU**

PART NUMBER: E361SXA201

**INSTALLATION  
INSTRUCTIONS**

**DESCRIPTION: KAYAK CARRIER**

**Step 1**

**(ROUND  
BARS  
ONLY)**



**Step 2**

**(ROUND  
BARS  
ONLY)**

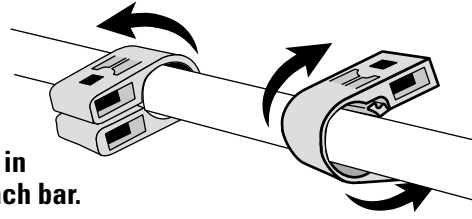

**Attach two SnapArounds in opposite directions on each bar.**

**Step 3**

**PLACE PADS ONTO BASES (ALL BARS).**

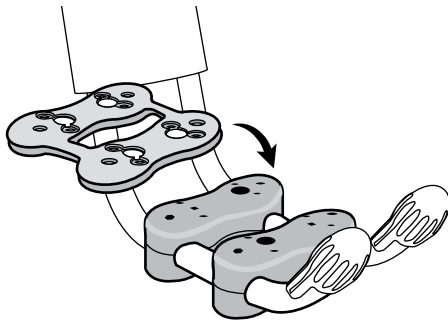

**Step 4**

**ATTACH PADS TO BASES WITH PLUGS.**

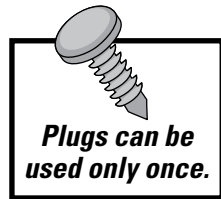
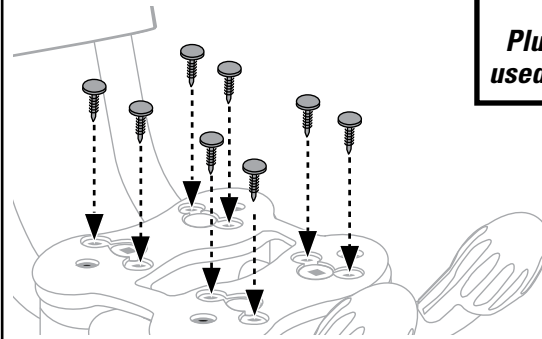

**Step 5 ALIGN SNAPAROUNDS ON MOUNTING CLAMPS TO LARGE HOLES IN BASE.**

- Insert bolts through large holes in base and into snaparounds.
- Make sure bolt is fully seated to install hex key.

**FOR AERO BAR MOUNTING CLAMPS  
USE BUTTON HEAD SCREWS**

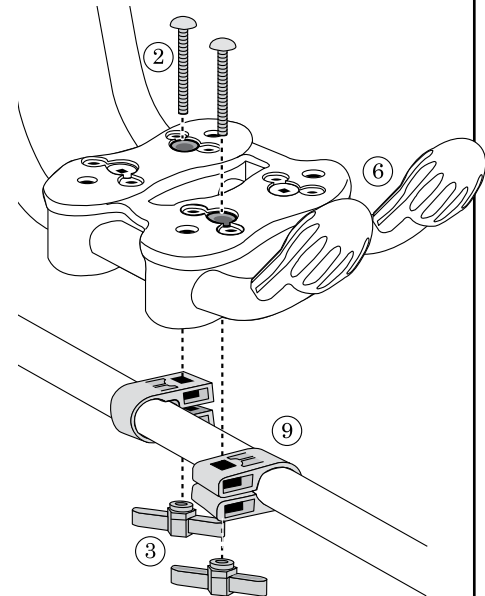
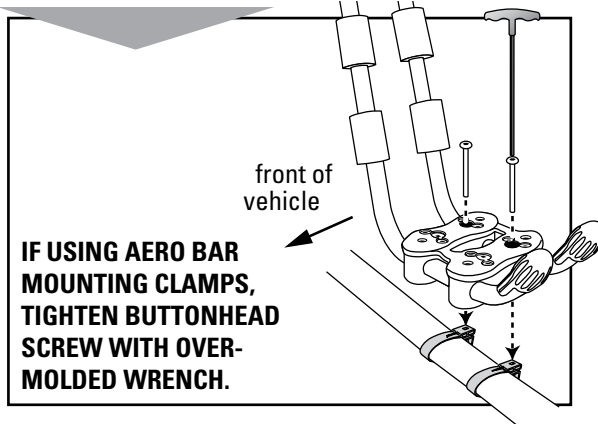

**MOUNT KAYAK CARRIERS AS CLOSE TO THE OUTSIDE OF THE VEHICLE AS POSSIBLE. ENSURE THAT THE CLAMPS ARE COMPLETELY ON THE CROSSBAR, AND NOT THE CROSSBAR END SUPPORTS.**



**SUBARU**

PART NUMBER: E361SXA201

**INSTALLATION  
INSTRUCTIONS**

**DESCRIPTION: KAYAK CARRIER**

**Step 6 ATTACH HEX KEYS ONTO BOLTS AND TIGHTEN.**

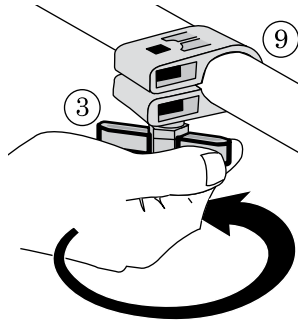

**Step 7 FOAM PADS CAN BE MOVED UP OR DOWN OR OFFSET TO SUPPORT KAYAK AT CONTACT POINTS.**

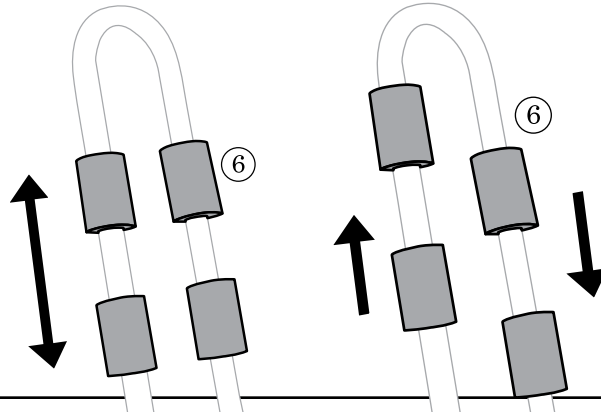

**Step 8 LOAD KAYAK AND TIE DOWN SECURELY.**

- Loop strap around hoop of kayak carrier.
- Bring straps up and over kayak so that they hang in front of the kayak.

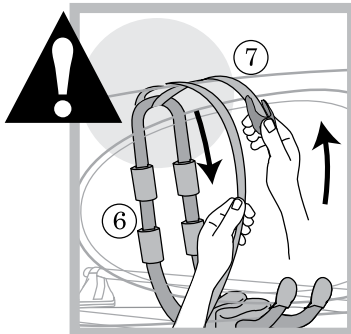

- Slide buckle up so that it hangs at top edge of kayak.
- Thread end of strap around tower or crossbar.

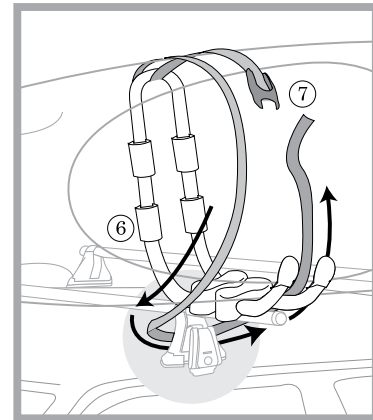

**Step 9 SECURE STRAPS.**

- Press open buckle.
- Insert end of strap.

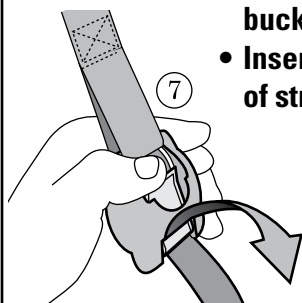

- To tighten straps, hold and pull.

**DO NOT OVERTIGHTEN STRAPS SO THAT THE KAYAK DEFORMS.**

**Tuck in ends of straps to prevent damage from straps flapping at speed.**

**POSITION BUCKLE SO THAT NOTHING CAN ACCIDENTALLY DISENGAGE IT.**

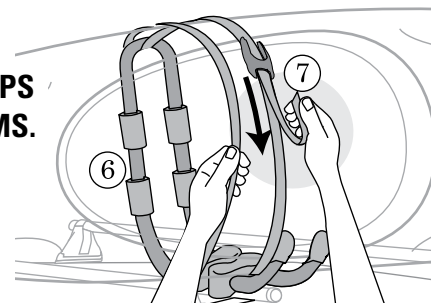



**SUBARU**

PART NUMBER: E361SXA201

**INSTALLATION  
INSTRUCTIONS**

DESCRIPTION: KAYAK CARRIER

**Step 10 BEFORE DRIVING AWAY:**

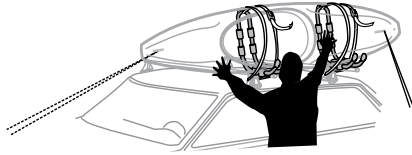

- **SECURE FRONT AND REAR OF KAYAK TO ENDS OF VEHICLE FOR SAFE TRANSPORT.**



- **TEST INSTALLATION BY ROCKING KAYAK. TIGHTEN AGAIN IF LOOSE!**

**CAUTION:**

- **FAILURE TO SECURE FRONT AND REAR OF KAYAKS TO ENDS OF VEHICLE CAN RESULT IN PROPERTY DAMAGE, PERSONAL INJURY, OR DEATH.**
- **ENSURE THAT THE STRAPS USED TO SECURE THE FRONT AND REAR OF THE KAYAK ARE ADEQUATE.**
- **ATTACHMENT HARDWARE CAN LOOSEN OVER TIME. CHECK AND TIGHTEN IF NECESSARY, BEFORE EACH USE, AND AT EACH STOP DURING YOUR TRIP.**
- **BE SURE ALL HARDWARE IS SECURED ACCORDING TO INSTRUCTIONS. FAILURE TO PERFORM SAFETY CHECKS BEFORE DRIVING AWAY CAN RESULT IN PROPERTY DAMAGE, PERSONAL INJURY, OR DEATH.**

**Attach the straps used to secure the front and rear of the kayak to a secure location on the vehicle, such as a tow hook or trailer hitch. Do not attach to a decorative, hot, or moveable part of the vehicle, such as the grill, exhaust system, or suspension components.**

**If any part of the straps used to secure the kayak rests on any painted surfaces (such as the bumper or hood), be sure to protect the vehicle paint from scratches in these areas.**

**REAR HATCH**

**Some longer kayaks may prevent the rear hatch from fully opening.**

**ALWAYS USE CAUTION WHEN OPENING YOUR HATCH.**

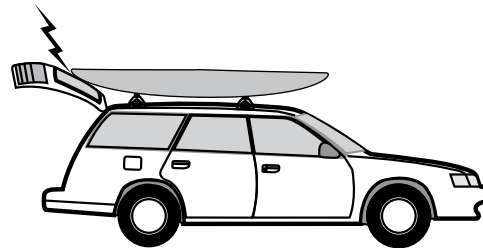

**MAINTENANCE: Use non-water soluble lubricant on screws. Use a soft cloth with water and mild detergent to clean plastic parts.**

**REMOVE ACCESSORY BEFORE ENTERING AN AUTOMATIC CAR WASH.**

**RETAIN THESE INSTRUCTIONS FOR FUTURE USE.**